

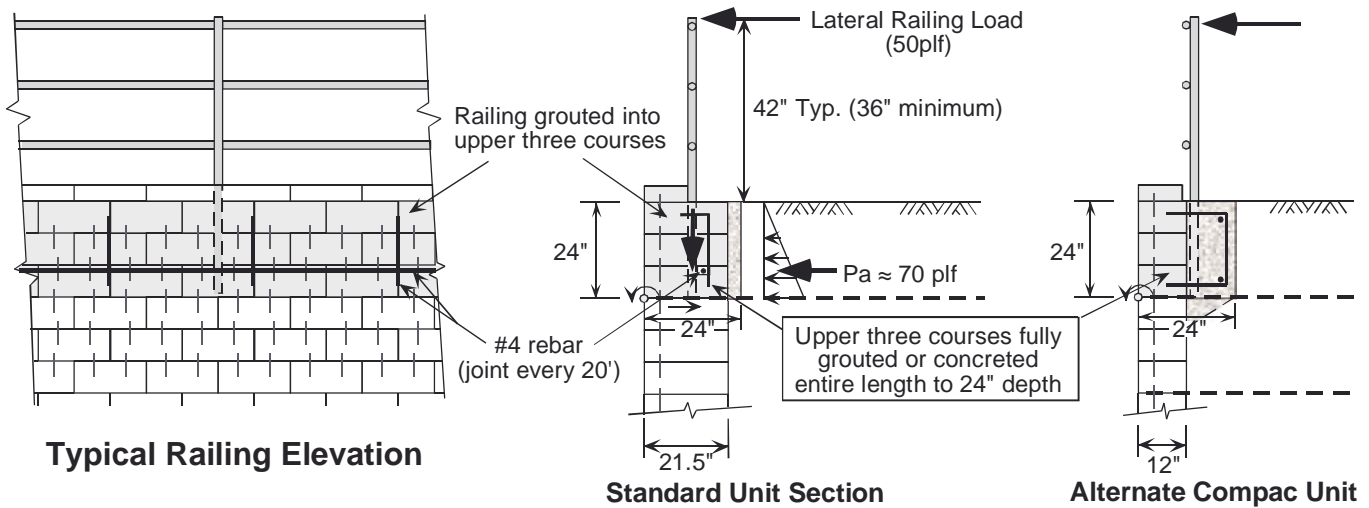

Typical Railing Design

Direct Mount - 50 plf - Standard/Compac Units



Typical Railing Design Section

Introduction

It is difficult for a railing design to satisfy structural design requirements when considering the direct mounting on or into the Keystone modular wall system. The small unit size and mass provides minimal resistance to overturning by itself so additional mass must be engaged to provide the required resistance. Modular wall units are typically not large enough to satisfy a 50 plf AASHTO/UBC lateral design loading without additional structure.

Railing Analysis

Shear resistance of Standard units (>1000 plf) and Compac units (>600 plf) exceeds the driving forces by a wide margin in gravity wall applications and is not a critical evaluation. Overturning at the top of wall (local stability) is the critical evaluation. A 50 plf or greater loading typically requires the addition of concrete and reinforcement for mass and strength.

Driving Moments (50 plf load)

Railing	50 plf x 5.5' arm	= 275 ft-lbs/ft
Soil	70 plf x 0.67'	= 47 ft-lbs/ft
Total		= 322 ft-lbs/ft

Resisting Moments (units filled with grout @ 140 pcf)

2' x 2' x 140 pcf x 1.0'	= 560 ft-lbs/ft
0.33' x 0.88' x 120 pcf x 0.44'	= 15 ft-lbs/ft
Total	= 575 ft-lbs/ft

SFot = 575/322 = 1.78 < 1.50 minimum, **OK**

Design Note:

Keystone Standard units are always recommended in situations where railings are considered for direct mounting on the wall system.

Keystone Compac units require additional reinforcement and concrete to provide the overturning mass necessary to resist design loadings. Compac unit designs should consider offset railings as a simpler and more economical alternative.